

PALCM

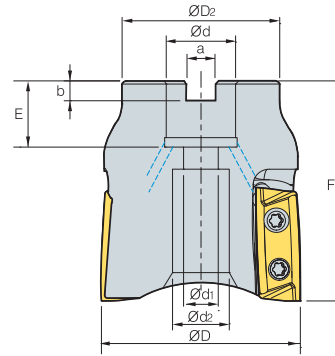

Designation		ØD	ØD ₂	Ød	Ød ₁	Ød ₂	a	b	E	F	ap	
PALCM 063HR	4	63	50	22	11	21	10	6.3	20	70	34	0.57

Available inserts

LXET-MA LXET-ML

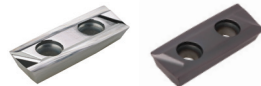

Designation	Cermet		Coated											Uncoated			page	
	CN2000	CN30	NCM325	NC5330	NCM535	NCM545	PC2505	PC2510	PC3600	PC3700	PC6510	PC9530	PC9540	PC5300	PC5400	ST30A		G10
LXET 340504PEFR-63-MA																		
3405PEFR-63-MA																		●
340512PEFR-63-MA																		
340516PEFR-63-MA																		
340504PEER-63-ML																		
3405PEER-63-ML																		
340512PEER-63-ML																		
340516PEER-63-ML																		

Available arbors

Designation	Ød	Available arbors
PALCM 063HR	22	BT□□-FMC22-□□

Parts

Specification		
Ø63	FTGA0511-P	TW20-100

Available inserts E12 Available arbors and bolt E400~E402